



INTERMARINE

# SHIP PARTICULARS

## 8K-400

Name	Built	IMO-No.	Flag	Name	Built	IMO-No.	Flag
Industrial Challenger	2000	9213935	Antigua & Barbuda	Industrial Charger	2000	9213959	Antigua & Barbuda

### GENERAL INFORMATION

Type	Box-Hold MPP TWD
Class	RINA

### TONNAGE

DWT	8,034 mt
GT	7,252 mt
NT	2,982 mt

### MAIN DATA

LOA	119.8 m
Beam	20 m
Summer Draft	7.70 m
Max Speed	16.0 knots

### HOLDS/HATCHES

Number	3 Holds / 1 Hatch
Hold No.1	12.75 x 10.41 m x 9.67 m
Hold No.2	38.40 x 15.75 m x 12.19 m
Hold No.3	12.90 x 15.75 m x 9.67 m
Hatch No.1	72.25 x 16.25 m

### CARGO CAPACITY

with Tweendeck	10,532 cbm / 371,934 cbft	Bale
----------------	---------------------------	------

### FLOOR SPACE

Under Deck	2,155 m <sup>2</sup>
On Deck	1,133 m <sup>2</sup>
Total	3,288 m <sup>2</sup>

### MAX. PERMISSABLE LOAD

Tanktop	15 mt/m <sup>2</sup> (11 mt/m <sup>2</sup> 1 + 3)
Tweendeck	3.5 mt/m <sup>2</sup>
Hatchcovers	2.5 mt/m <sup>2</sup>

### CONTAINERS CAPACITY

Total	516 TEU / 250 FEU
Reefer Plugs	80 / 12 kW

### CARGO HANDLING GEAR

Cranes	2 x 200 mt (portside)
Combined Lift Capacity	400 mt

### SPECIAL EQUIPMENT/FEATURE

IMO fitted	Yes
Lakes Fitted	No
CO2 Fitted	Yes
A60 Bulkhead	
Grain Fitted	No
Bowthruster	450 kW

All details including speed are given in good faith and can vary on the individual vessels. They are to be considered „about“, are given without guarantee and must not be used as basis for charterparties or contracts without Intermarine's explicit written authority. For further information, please contact [info@intermarine.com](mailto:info@intermarine.com) // Last Revised: March 2024

**8K-400**

**INDUSTRIAL CHALLENGER  
INDUSTRIAL CHARGER**

**BACK**

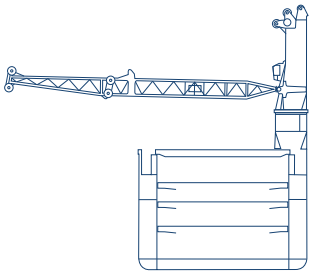

**SIDE**

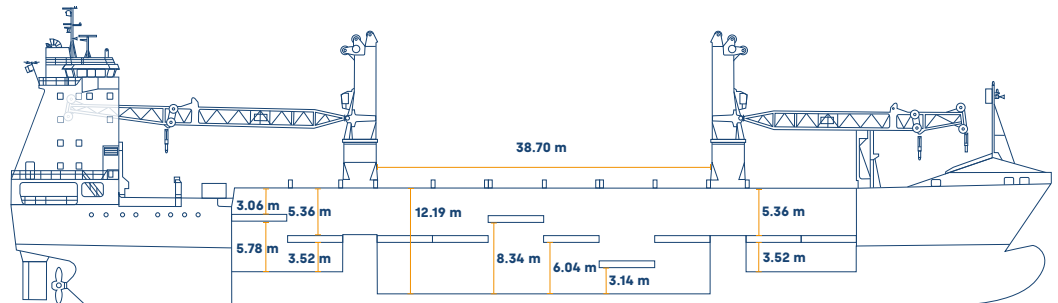

**MAINDECK**

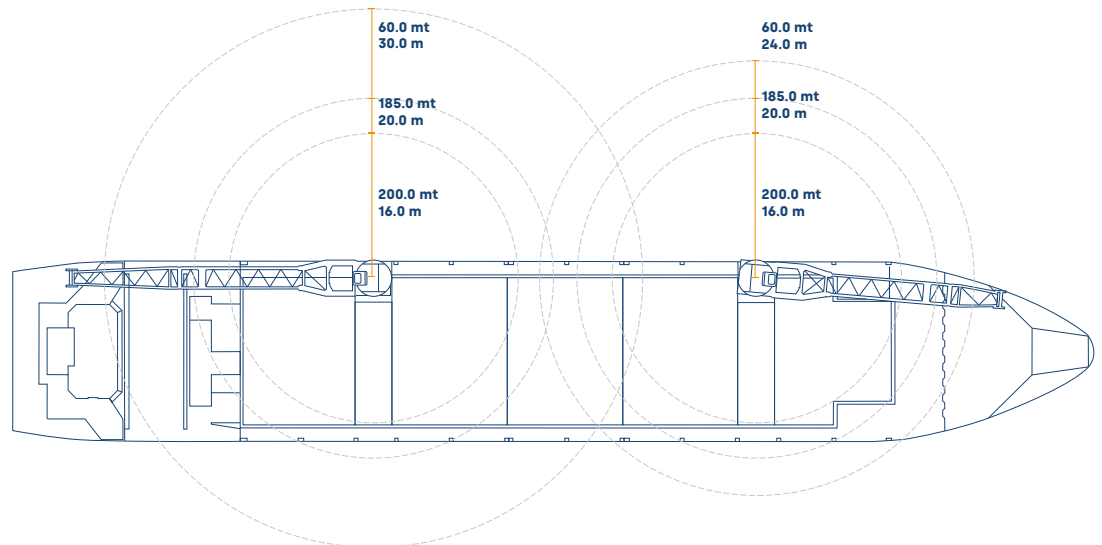

**TWEENDECK**

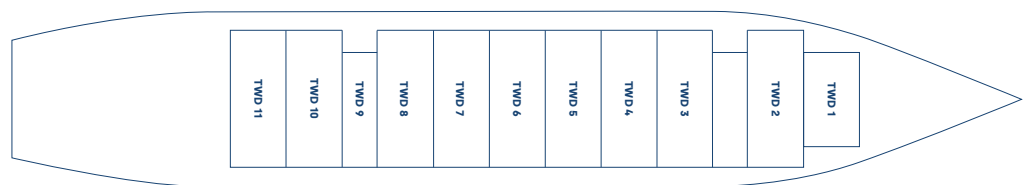

**TANKTOP**

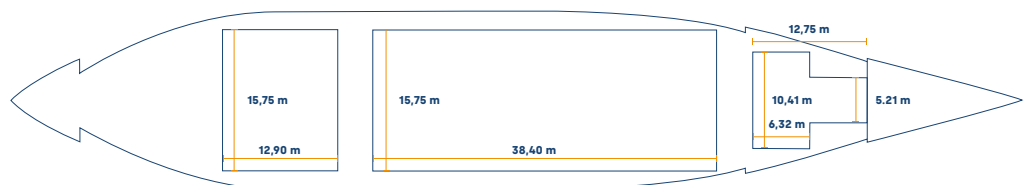

All details including speed are given in good faith and can vary on the individual vessels. They are to be considered „about“, are given without guarantee and must not be used as basis for charterparties or contracts without Intermarine’s explicit written authority. For further information, please contact [info@intermarine.com](mailto:info@intermarine.com) // **Last Revised: March 2024**